

747-8 Freighter

World's most capable freighter

Able to carry higher loads for greater revenue and profitability

Most capable freighter including high-hot capability

The only commercial freighter in production with nose loading capability

Revenue Payload: 133.2 tonnes

133.2 tonnes = 146.8 US tons

Range: 4,265 Nautical Miles with Max load of 133.2 Tonnes

Range increases as payload is decreased

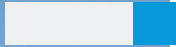

ADDITIONAL DETAILS

747-8 Freighter

747-8F carries 34 main deck pallets

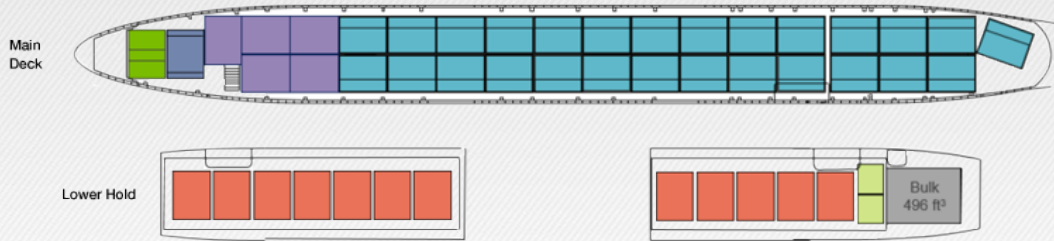

[Back to Top](#)

	ULD Type	Capacity ft ³ (m ³)	Tare lb. (kg)	Deck	Cargo Volume
27	96" x 125" x 118" pallet	750 (21.2)	300 (136.1)	Main Deck	24,462 ft ³ (692.7 m ³)
5	96" x 125" x 96" pallet	613 (17.4)	300 (136.1)	Main Deck	
1	96" x 125" x 96" pallet	607 (17.2)	300 (136.1)	Main Deck	
1	96" x 125" x 96" pallet	540 (15.3)	300 (136.1)	Main Deck	
12	96" x 125" x 64" pallet	415 (11.8)	290 (131.5)	Lower Hold	5,826* ft ³ (165.0* m ³)
2	LD-1 Container	175 (5.0)	200 (90.7)	Lower Hold	

Total Cargo Volume

30,288 ft³ (857.7 m³)

Total Tare Weight

14,080 lb (6,387 kg)

[ADDITIONAL DETAILS](#)

747-8 Freighter

The large nose cargo door simplifies loading of outsized cargo

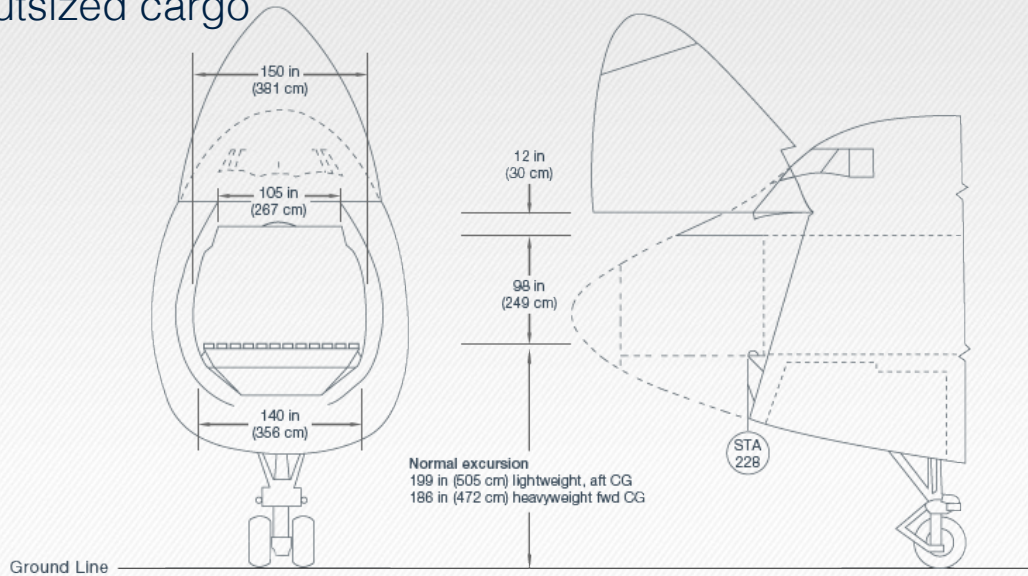

[Back to Top](#)

[CLICK HERE TO CLOSE NOSE DOOR](#)

[ADDITIONAL DETAILS](#)

747-8 Freighter

747-8F carries 3-meter (10-ft) tall pallets

[Back to Top](#)

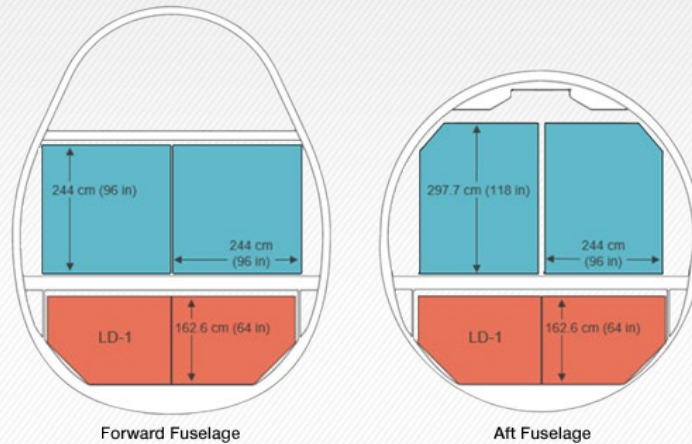

ADDITIONAL DETAILS

747-8 Freighter

777F and 747F use same ground handling system for commonality

777F

5.4 m
(17.6 ft)

118 in (300 cm)
10ft (-3m)

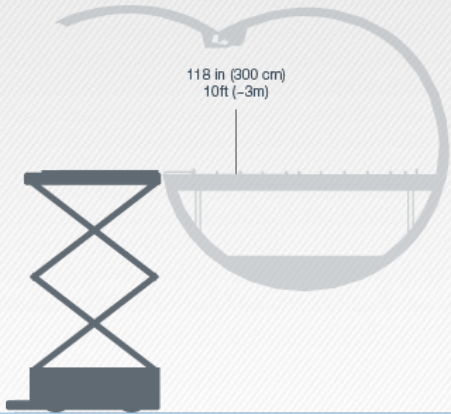

5.1 m
(16.8 ft)

118 in (300 cm)
10ft (-3m)

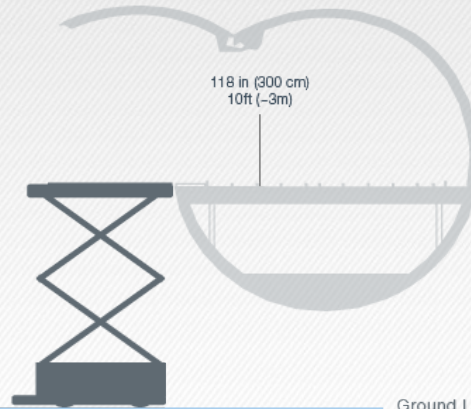

Back to Top



Ground Line

ADDITIONAL DETAILS



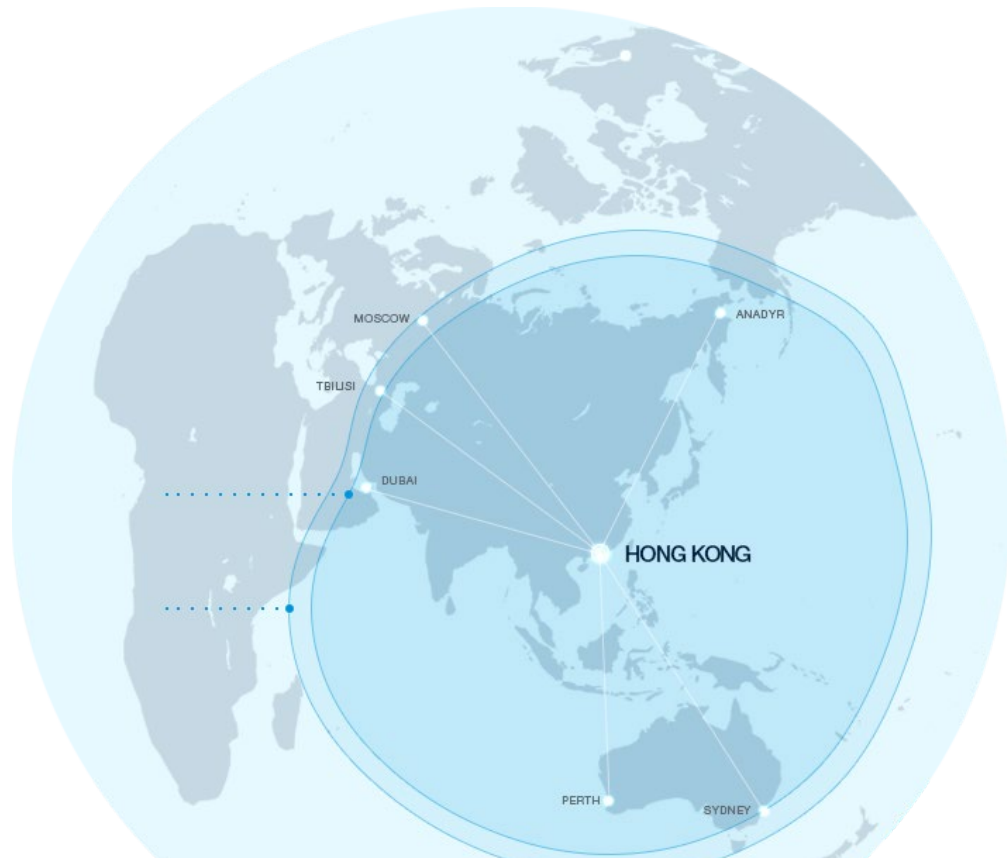





747-8 Freighter

747-8F Characteristics



[Back to Top](#) 

68.4 M / 224 ft 5 in
WINGSPAN

19.4 M / 63 ft 6 in
HEIGHT

76.3 M / 250 ft 2 in
LENGTH

Payload
137.7 metric tons (303,700 LB) = 151.8 US Tons

Range
4,120 nm based on maximum payload

[ADDITIONAL DETAILS](#)